

DO NOT DISCARD!

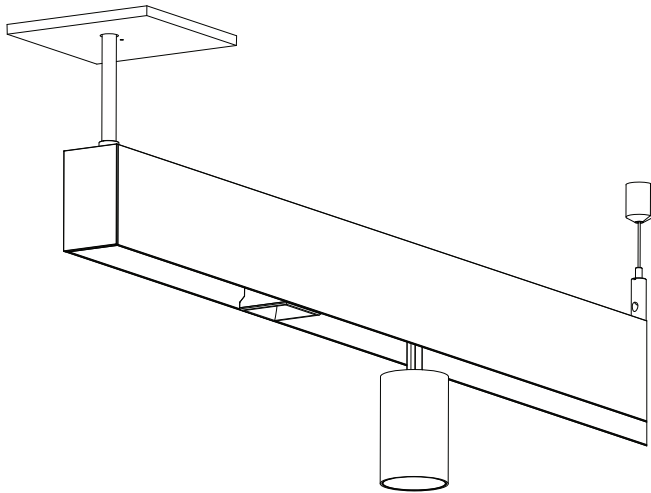

SIGN LEGEND

- power OFF
- power ON
- don't touch the LEDs
- attention
- use anti-static gloves

TOOLS REQUIRED (not included)

- pencil
- level
- screwdriver
- drill
- anti-static gloves

POWER SUPPLY DIMENSIONS

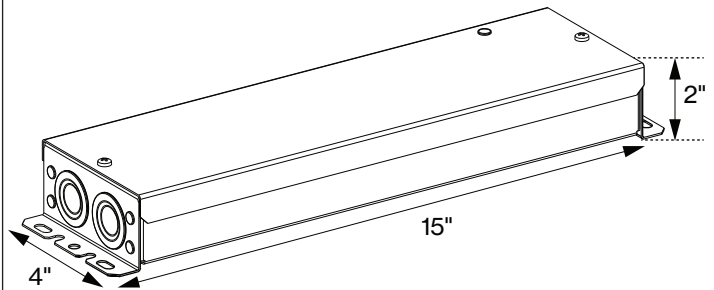

R-LINE
PENDANT R1

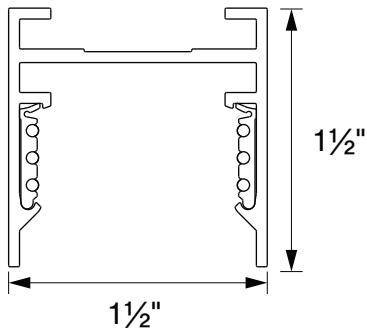

R-LINE
PENDANT R2

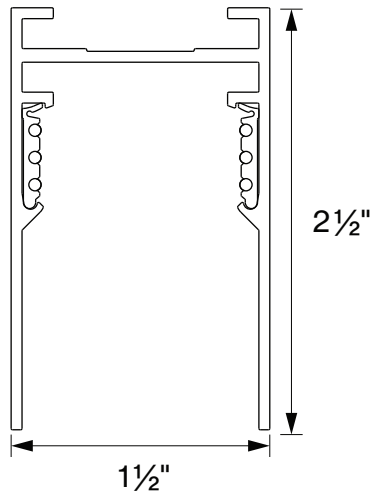

R-LINE
PENDANT R3

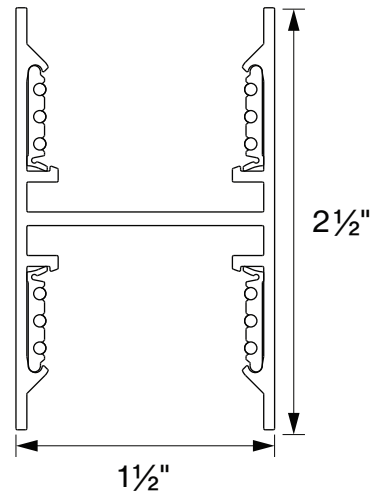

<p>Turn OFF power source before installation</p>	<p>1. Layout track(s) and mark mounting points</p>	<p>2. Assemble barrel mount and rope fixation</p>
<p>3. Click rope fixation into top of track.</p>	<p>4. Adjust aircraft cables to proper height. (Can also be adjusted at the base of the barrel mount.)</p>	<p>5. Trim aircraft cables once tracks have been leveled</p>
<p>6. Insert feeder through hole in track</p>	<p>7. Thread aircraft cable through bracket</p>	<p>8. Thread aircraft cable through cover</p>
<p>9. Thread feeder through cover plate</p>	<p>10. Thread feeder through bracket</p>	<p>11. Use screws to secure strain relief</p>
<p>12. Place bracket into junction-box</p>	<p>13. Splice the cables in the j-box with wire nuts</p>	<p>14. Screw bracket into J-box</p>

15. Click cover onto mounting plate springs

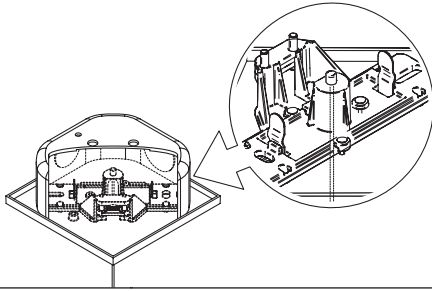

16. Install converter box (ceiling / utility room). See page 4 chart for max. distance

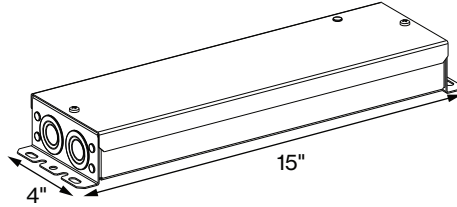

17. Feed the cables into the power supply

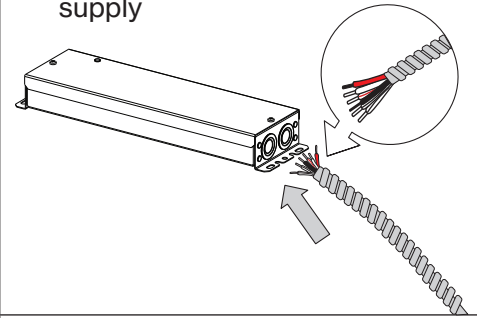

Please see wiring diagram on page 5

18. Insert linear connector

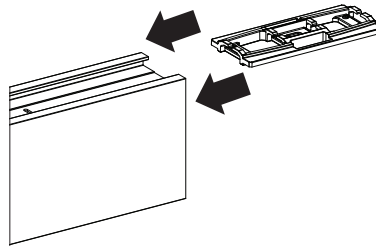

19. Use screws to secure connector

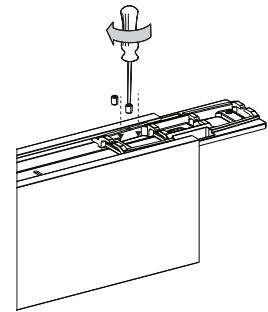

20. Slide next track onto linear connector

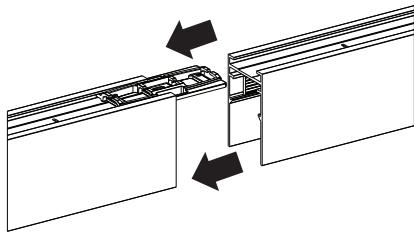

21. Use screws to secure connector again

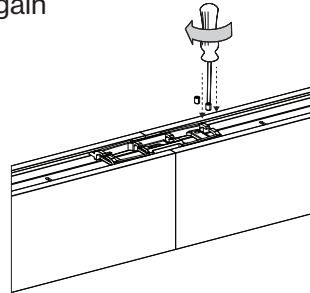

22. Snap track connectors into tracks

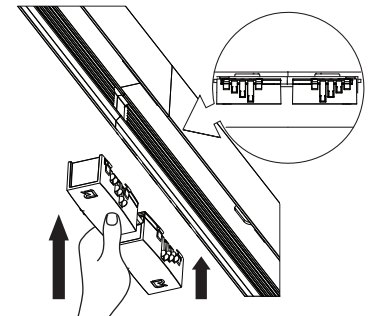

23. Snap insets into tracks

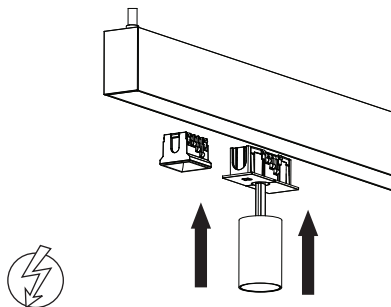

24. Installation complete

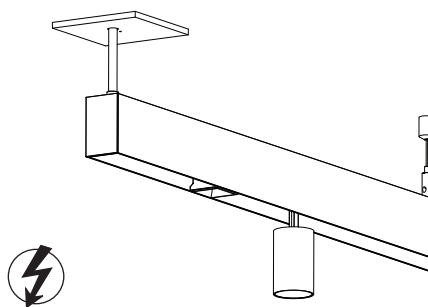

Technical Support Hotline

The XAL Technical Support Hotline is available from Monday to Friday, 8 AM - 6 PM (EST)

Hotline: **+1 203 262 9990**

Email: **service@xalusa.com**

Please refer to the next page for the instructions on installing the **R-LINE indirect feed**.

MOUNTING INSTRUCTIONS

Please note that the following instructions are for installing the **optional indirect feed** and are not necessary for installing the direct feed for R-LINE.

24. Snap indirect feeder into the channel

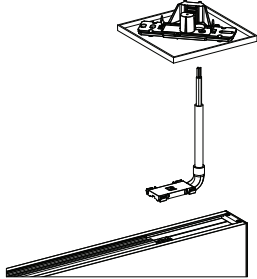

25. Click feeder suspension cable to the track

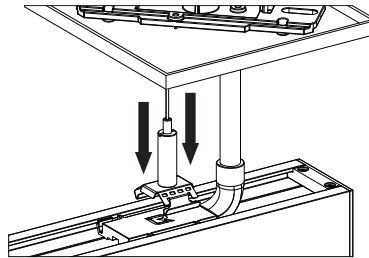

25a. Note: Additional suspension cables be clicked into any channels that have the R-LINE logo

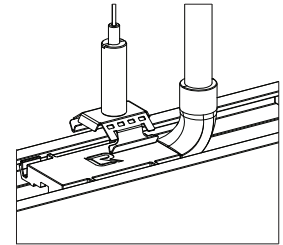

26. Align the indirect connector with the linear connector from above

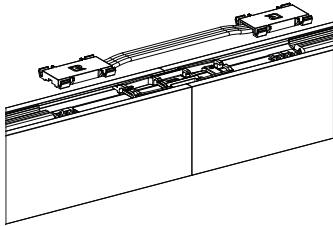

27. Snap the indirect connector to the linear connector. Follow steps 22 and 23 to complete installation.

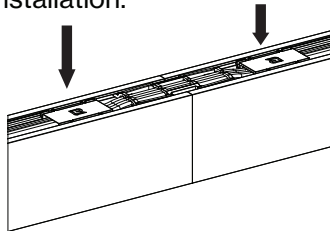

Technical Support Hotline

The XAL Technical Support Hotline is available from Monday to Friday, 8 AM - 6 PM (EST)

Hotline: **+1 203 262 9990**

Email: **service@xalusa.com**

WIRING DIAGRAMS

POWER TRACK - NO DIMMING

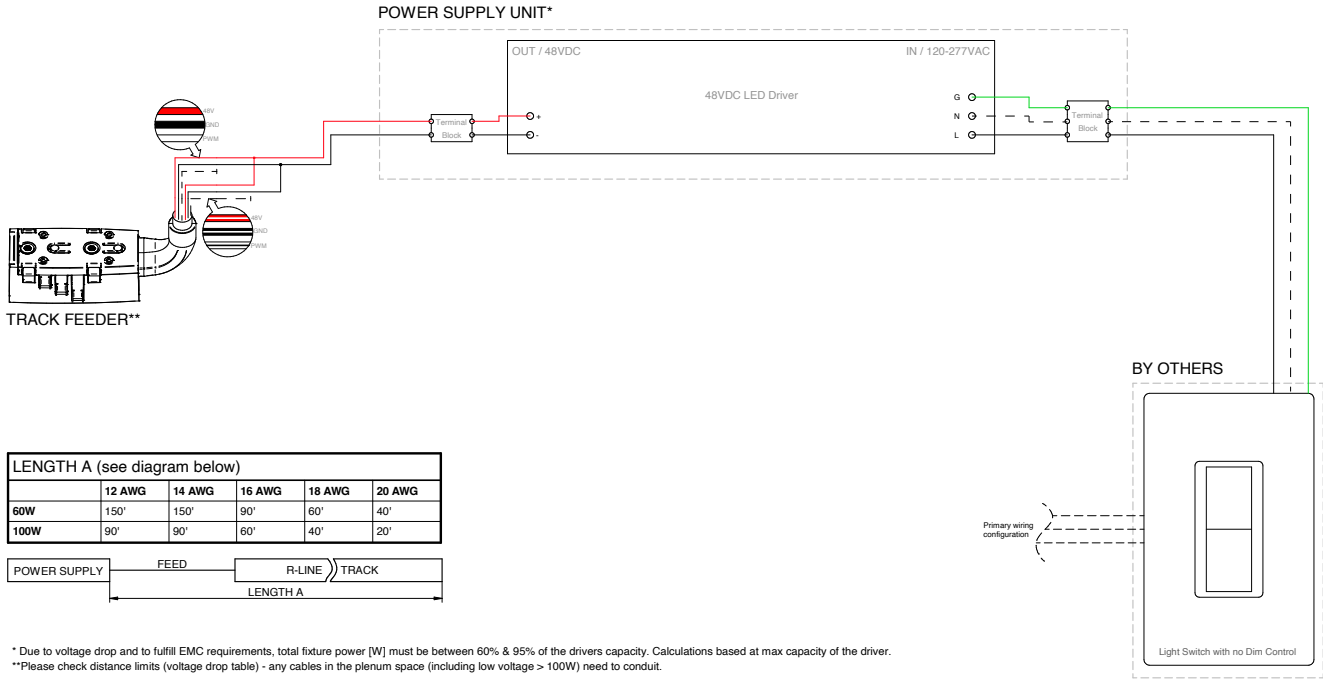

POWER TRACK - SINGLE CIRCUIT DIMMING 0-10V

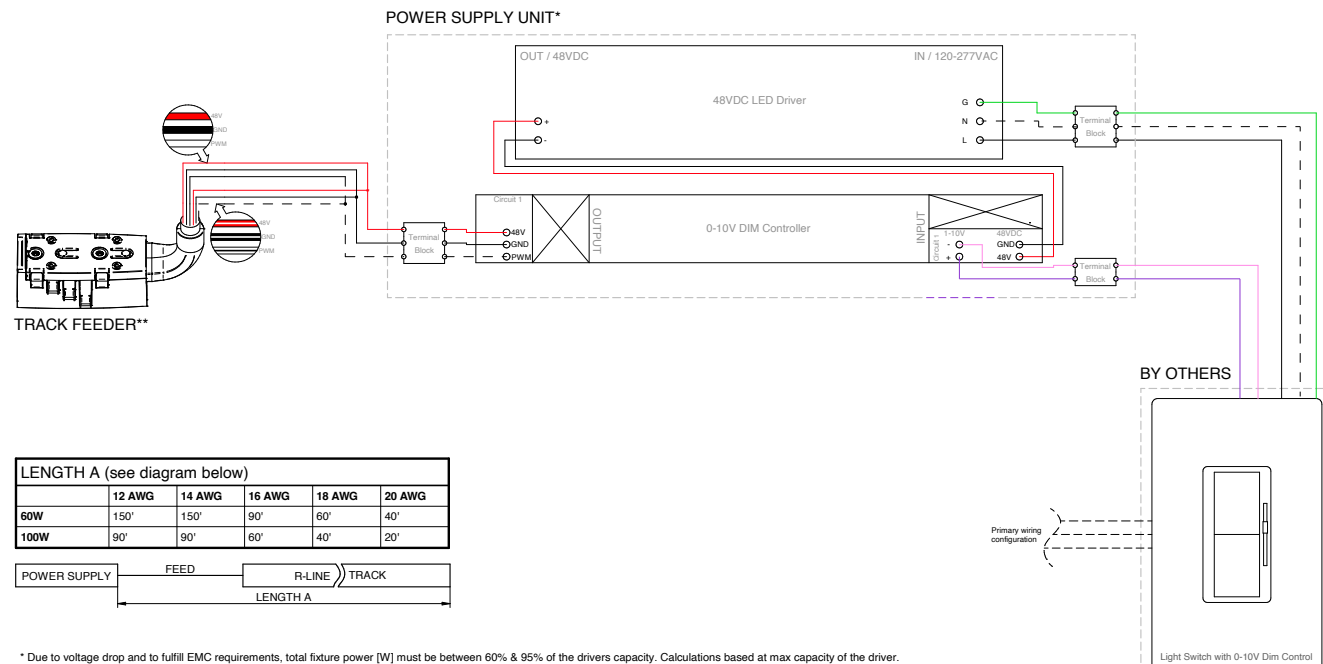

WIRING DIAGRAMS

INDIRECT UPLIGHT - SINGLE CIRCUIT NO DIMMING

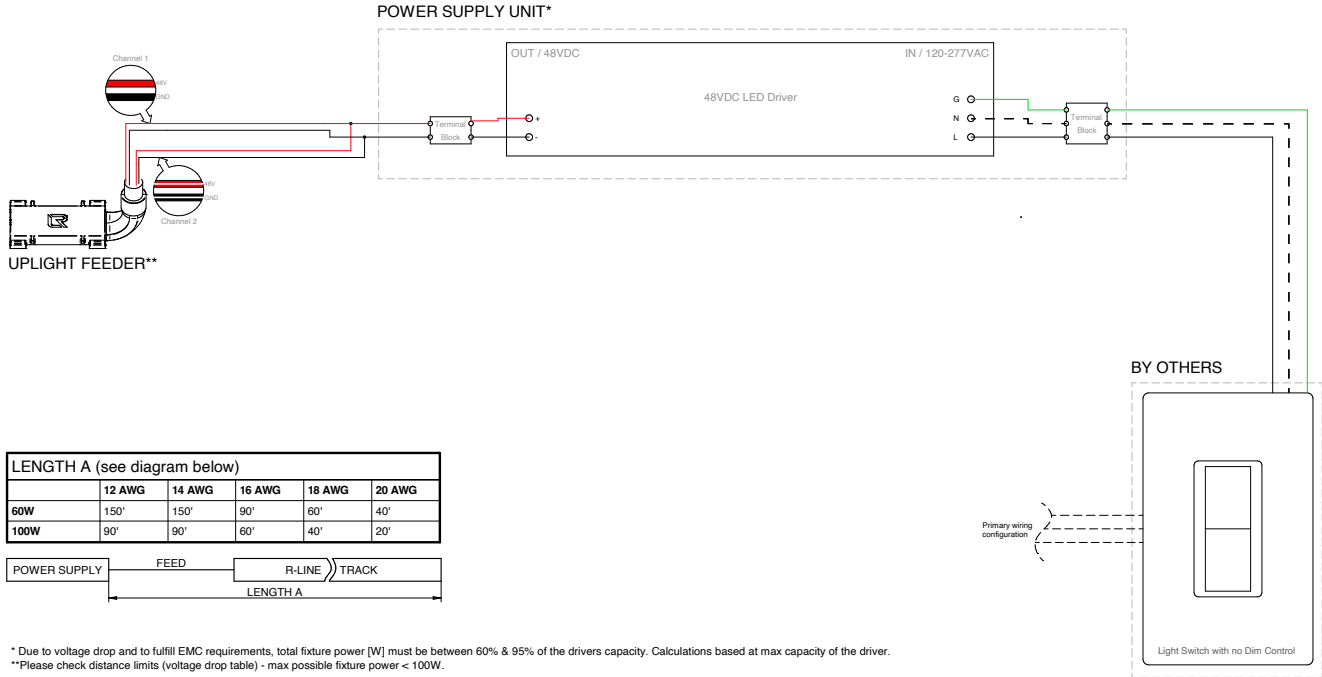

* Due to voltage drop and to fulfill EMC requirements, total fixture power [W] must be between 60% & 95% of the drivers capacity. Calculations based at max capacity of the driver.
 **Please check distance limits (voltage drop table) - max possible fixture power < 100W.

INDIRECT UPLIGHT - SINGLE CIRCUIT DIMMING 0-10V

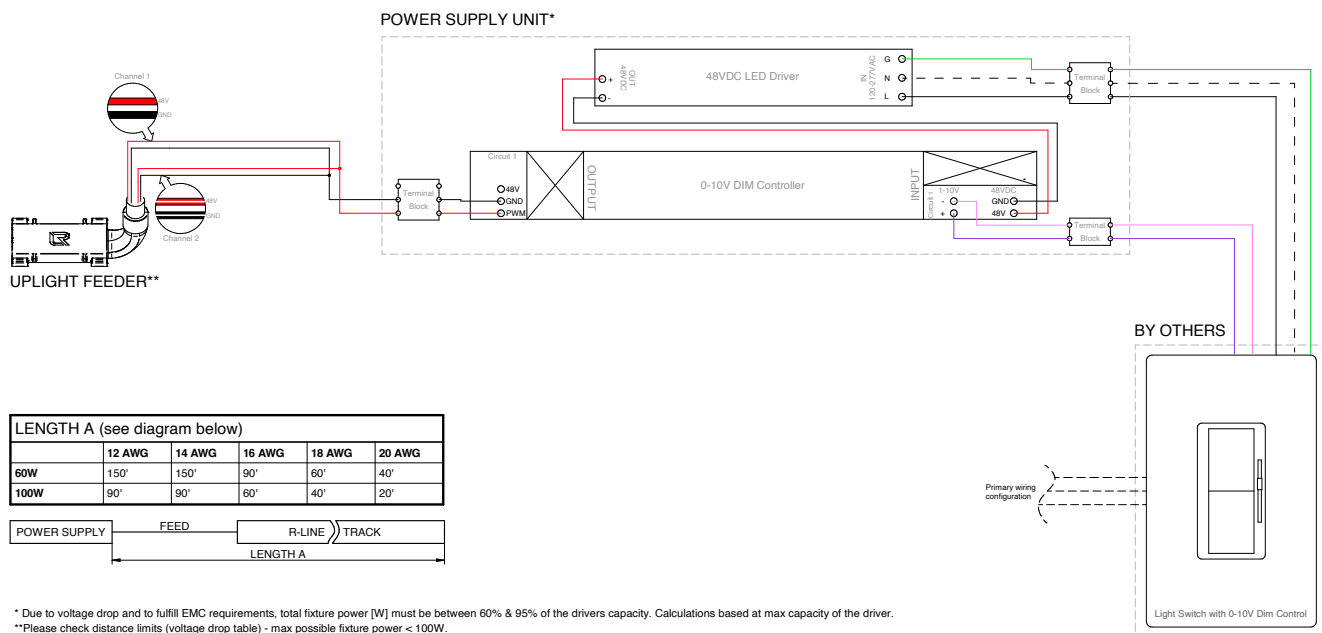

* Due to voltage drop and to fulfill EMC requirements, total fixture power [W] must be between 60% & 95% of the drivers capacity. Calculations based at max capacity of the driver.
 **Please check distance limits (voltage drop table) - max possible fixture power < 100W.

WIRING DIAGRAMS

POWER TRACK - SINGLE CIRCUIT, DIAL CHANNEL DIMMING 0-10V

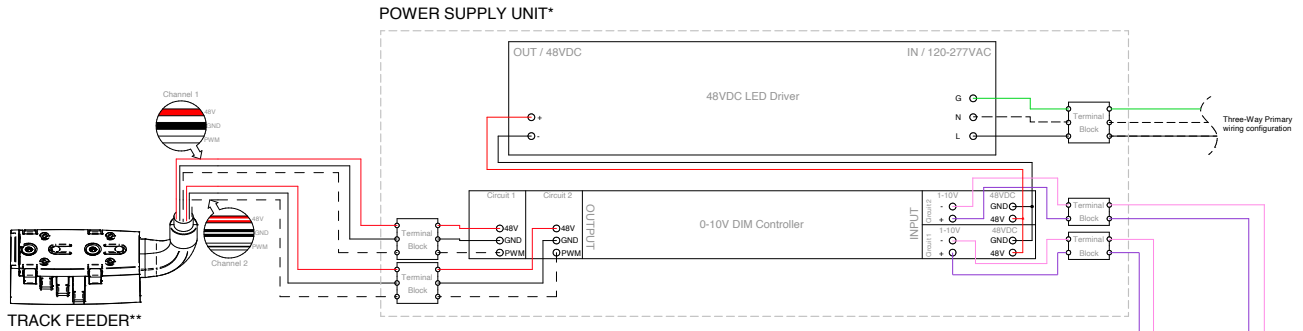

TRACK FEEDER**

LENGTH A (see diagram below)					
	12 AWG	14 AWG	16 AWG	18 AWG	20 AWG
60W	150'	150'	90'	60'	40'
100W	90'	90'	60'	40'	20'

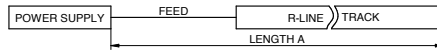

* Due to voltage drop and to fulfill EMC requirements, total fixture power [W] must be between 60% & 95% of the drivers capacity. Calculations based at max capacity of the driver.
 **Please check distance limits (voltage drop table) - any cables in the plenum space (including low voltage > 100W) need to conduit.

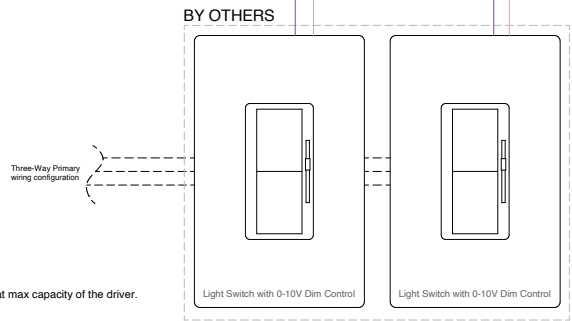

POWER TRACK - DUAL CIRCUIT (2C), DIMMING 0-10V (SHARED TRACK FEEDER)

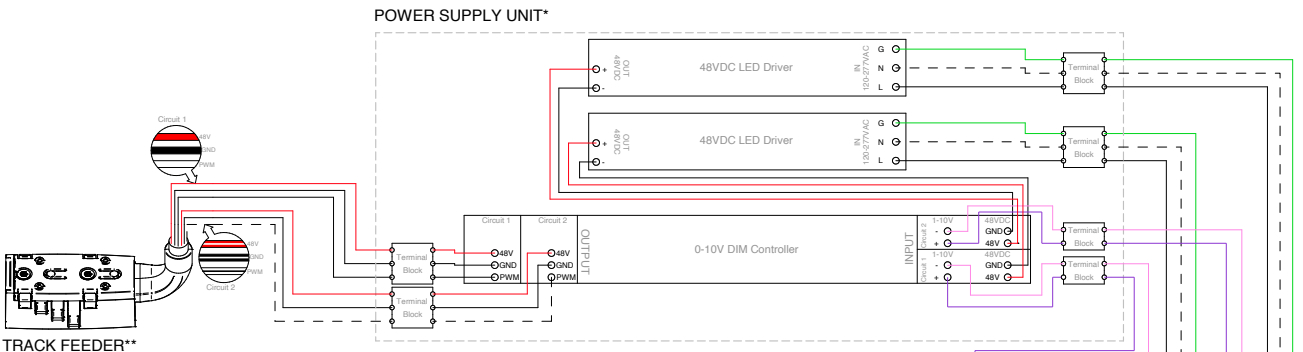

TRACK FEEDER**

LENGTH A (see diagram below)					
	12 AWG	14 AWG	16 AWG	18 AWG	20 AWG
60W	150'	150'	90'	60'	40'
100W	90'	90'	60'	40'	20'



* Due to voltage drop and to fulfill EMC requirements, total fixture power [W] must be between 60% & 95% of the drivers capacity. Calculations based at max capacity of the driver.
 **Please check distance limits (voltage drop table) - any cables in the plenum space (including low voltage > 100W) need to conduit.

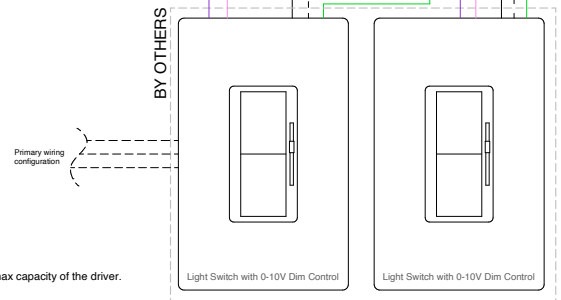

WIRING DIAGRAMS

POWER TRACK UPLIGHT - DUAL CIRCUIT, DIAL CHANNEL, DIMMING 0-10V (SEPARATE UPLIGHT FEEDER)

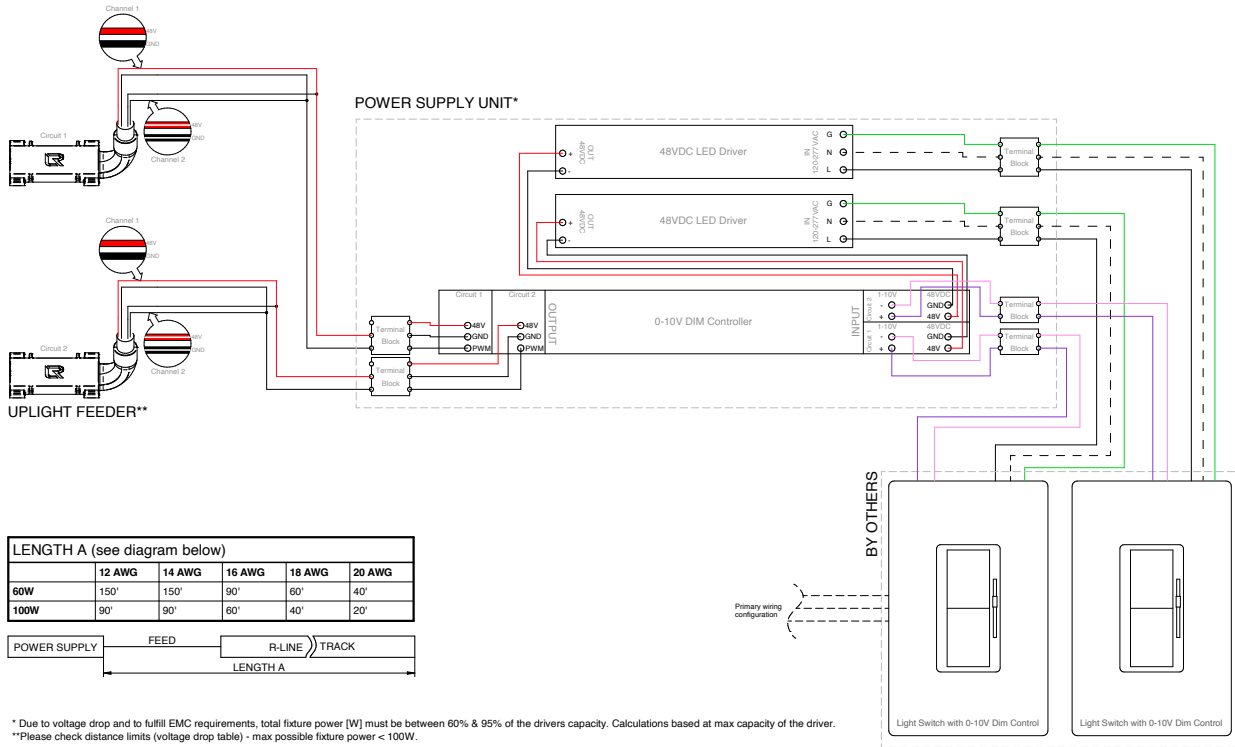

POWER TRACK -DUAL CIRCUIT (2C), DIMMING 0-10V (SEPERATE TRACK FEEDER)

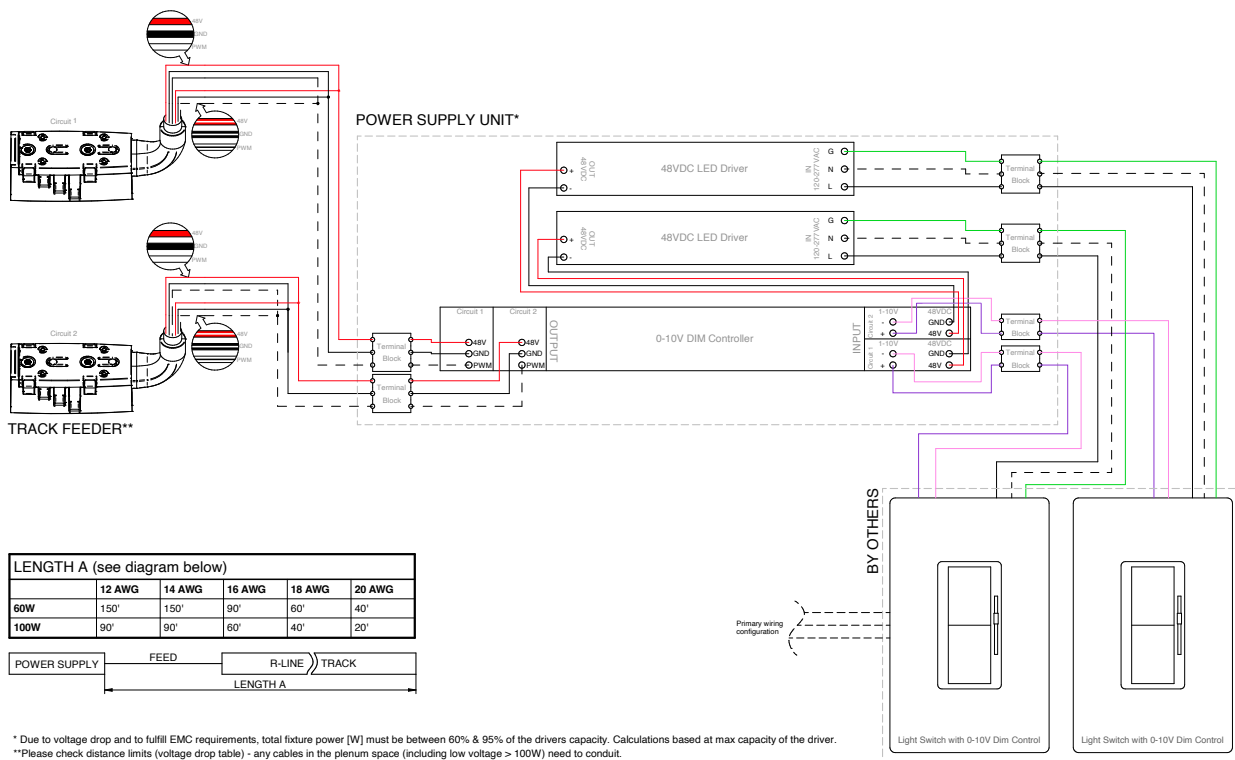

Technical Support Hotline

Call the XAL Technical Support Hotline from Monday to Friday, 8 AM - 6 PM (EST)

Hotline:
+1 203 262 9990

Or 24/7 via email:
service@xalusa.com

EN Installation, commissioning and maintenance may only be performed by authorized and qualified personnel, taking into consideration these installation instructions and any standards and regulations applicable to the respective area of application. The electrical, mechanical and thermal suitability of the luminaire for the intended area of application must be ensured and the secure fastening of the luminaire after its installation must be controlled. Turn off supply voltage before replacing any lamps (if applicable) as well as before performing any other works on the luminaire (e.g. cleaning) and wait until luminaire and lamp have completely cooled off. Please refer to the installation notes of the lamp manufacturer when inserting, replacing and operating conventional lamps. Use a soft, damp cloth to clean the luminaire. To clean plastic components and reflectors, a standard pH neutral, alcohol-free, non-abrasive cleaning agent may also be used. Keep these installation instructions in a safe place as reference for any future maintenance works.

1. The lamp is not suitable for outdoor use.
2. The lamp may only be used with a safety guard.
3. Damaged protection glasses and covers have to be replaced immediately.
4. Corrosive chemical products must not be used as this may have a detrimental effect on the luminaire.
5. No liability is accepted for any subsequent change of the luminaire.
6. LEDs are high-quality electronic components! Please avoid touching by hand the LED light emitting surface while assembling or replacing parts and during maintenance work.
7. To avoid damage of the profile, unevenness on the wall or ceiling must be leveled out before assembling the profiles. While assembling the profiles, make sure they do not deform in order to guarantee their proper function.
8. The light source contained in this luminaire shall only be replaced by the manufacturer or his service agent or a similar qualified person.
9. The LED circuit must always be closed, before the converter is connected to the main power. XAL does not assume any liability for damages resulting from nonobservance of this rule.
10. Luminous flux and connected electrical load are subject to an initial tolerance of up to +/- 10%. Color temperature is subject to a tolerance of up to +/- 150 Kelvin from the nominal value.

FR Le montage et la maintenance peut être effectué par spécialistes respectant les normes y règles valides. Assurer l'aptitude thermique, mécanique et électrique pour l'emploi prévue et assurer la fixation de la luminaire. Éteindre la tension avant de changer les lampes (si applicable) ou avant de réaliser travaux (p.ex nettoyage) à la luminaire. Attendre jusqu'à ce que la luminaire et les lampes ont fraîchit complètement. Merci de bien vouloir vous référer aux notes d'installation du fabricant de la lampe lors de l'insertion, le remplacement et la mise en route, avec des lampes conventionnelles. Pour nettoyer la luminaire utiliser un drap humide et doux. Pour nettoyer les parties du plastique ou les réflecteurs on peut utiliser encore un produit de nettoyage sans alcool qui ne fraye pas le material. Garder cette notice de montage pour possibles travaux de maintenance.

1. La luminaire n' est pas apte pour l'utilisation exterieur.
2. Utiliser la luminaire seulement avec un dispositif de sécurité
3. Changer immédiatement des verres de sécurité defectes ou bien des écrans de protection.
4. Evitez tout contact de la lampe avec de produits chimiques corrosifs.
5. Nous déclinons toute responsabilité en cas de modifications ultérieures.
6. Des LEDs sont des composants électroniques de haute qualité! Eviter tout contact direct de la surface de sorti de lumière de la LED avec les mains lors du montage ou des les travaux de maintenance de la lampe.
7. Pour éviter l'endommagement du profil, il est nécessaire de compenser les irrégularités du mur ou du plafond avant le montage des profils. Pour garantir un fonctionnement irréprochable des profils, il ne faut pas déformer les profils lors du montage.
8. La source du luminaire peut être remplacé uniquement par le fabricant ou un tiers habilité.
9. Il faut que le circuit de LED soit fermé avant de connecter le convertisseur. XAL ne assume pas la garantie si cette norme ne se respecte pas.
10. La puissance et le flux lumineux affichent d'origine une tolérance de +/- 10 %. Tolérance de la couleur de température : +/- 150 Kelvin.

ES La instalación, la puesta en marcha y el mantenimiento sólo deben realizarse por personal especializado considerando esta guía de instalación y todas las normas y reglamentaciones vigentes. Asegurarse de la aptitud eléctrica, mecánica y térmica de la luminaria para la aplicación prevista y comprobar la fijación segura de la luminaria después de su instalación. Apagar siempre la corriente antes de cambiar la lámpara (en caso justificado) o de realizar algún otro trabajo en esta (p.ej. Limpieza). Esperar hasta que se enfrien la luminaria y la lámpara completamente. Tener en cuenta las instrucciones de montaje del fabricante al colocar, cambiar y utilizar lámparas convencionales. Para la limpieza de la luminaria utilizar un paño suave y húmedo. Para limpiar componentes de plástico y reflectores puede usar también un limpiador pH neutral y sin alcohol que no roce el material. Guardar esta guía de instalación para trabajos de mantenimiento.

1. La luminaria no es apta para utilizarla en el exterior.
2. La luminaria sólo debe accionar con un dispositivo de seguridad.
3. Cambie de inmediato los vidrios y las tapas de protección dañados.
4. Químicos que tienen efectos corrosivos no deben influir en la luminaria.
5. Para modificaciones futuras en la luminaria no se asume ninguna responsabilidad.
6. Los LED son componentes electrónicos de alta calidad! Por favor durante el montaje o el mantenimiento evite el contacto directo con la superficie de emisión.
7. Para evitar daños en el perfil, los desniveles de las paredes y techos deben ser enrasados antes del montaje de los perfiles. Para garantizar su buen funcionamiento, los perfiles no deben sufrir deformaciones durante el montaje.
8. La fuente luminosa contenida en esta luminaria debe ser reemplazada únicamente por el fabricante o su agente de servicio o similar persona cualificada.
9. El circuito LED debe ser cerrado antes de conectar el convertidor. XAL no asume garantía si esta norma no se respeta.
10. I dati di flusso luminoso e potenza sono inizialmente passibili di tolleranze di +/- 10%. Tolleranza della temperatura di colore: +/- 150 Kelvin.

We reserve the right to change our products at any time. Current information is available at www.xalusa.com.

Nos reservamos en todo momento el derecho de realizar cambios en nuestros productos. n nuestra página web www.xalusa.com siempre se encontrarán datos actuales.

Nous nous réservons le droit de modifier à tout moment nos produits. Vous trouverez toujours toutes les informations actuelles sur www.xalusa.com.

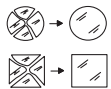

The lamp may only be operated with its full protective cover!

L'apparechio necessita del relativo vetro di protezione!

Sólo usar la luminaria con su cobertura de seguridad completa!



Recommended room temperature: 77 °F.
Temperatura ambiente recomendada: 77 °F.
Température ambiante recommandée: 77 °F.



Don't touch the LED



Use gloves.
Use guantes.
Utiliser des gants.